

Triple Scabbling Hammer

Operation and Maintenance Manual



DECLARATION OF CONFORMITY

We,
Trelawny SPT Limited of
Trelawny SPT Ltd, CO. Indutrade Benelux BV, Anton Philipsweg 1, 1422 AL Uithoorn,
Netherlands

Declare that under our sole responsibility for supply/manufacture of the product

Name of product

Model, Serial Number

Year of production

to which this document relates is in conformity with the provisions of the following
Directive(s), Normative Documents and their relevant Standards:

EN ISO 11148-4:2012

**HANDHELD NON-ELECTRIC
(Non-Rotary Percussive Tools)**

Year and place of issue,
2021
Leamington Spa, England



Adam Dickinson
Managing Director



DECLARATION OF CONFORMITY

We,
Trelawny SPT Limited of
Trelawny House, 13 Highdown Road, Sydenham Industrial Estate, Leamington Spa,
Warwickshire, CV311XT, United Kingdom

Declare that under our sole responsibility for supply/manufacture of the product

Name of product

Model, Serial Number

Year of production

to which this document relates is in conformity with the provisions of the following
Directive(s), Normative Documents and their relevant Standards:

EN ISO 11148-4:2012

**HANDHELD NON-ELECTRIC
(Non-Rotary Percussive Tools)**

Year and place of issue,
2021
Leamington Spa, England

**UK
CA**



Adam Dickinson
Managing Director

DOC. Q58B/1

CZ	<p>Prohlášení o přizpůsobení My, společnost Trelawny SPT Limited podajemy daňové přiznání, že výrobek a dodávka výrobku název výrobku Model, výrobní číslo Rok výroby Pro které se prokázá týkající, je přizpůsobení s zásobou od následující příkazové a jejich pohotovosti: 98/37/EC Příkaz soustrojí 73/23/EC Příkaz nízkého napětí (upotřebitelné jediné do výrobku použití elektrické energie)</p>	LT	<p>ATITIKTIES DEKLARACIJA Mes, Trelawny SPT Limited Prisiimdami visa atsakomybę, deklaruojame, kad tiekiamas / gaminamas produktas Produkto pavadinimas Modelis, serijos numeris Pagaminimo Kuriam taikoma ši deklaracija, atitinka šių direktyvų, norminių aktų ir su jais susijusių standartų reikalavimus: 98/37/EC Įrangos direktyva 73/23/EC Žemos įtampos direktyva (taikoma tik elektriniams įrengimams)</p>
DE	<p>Übereinstimmungserklärung Wir, Trelawny SPT Limited erklären, dass unter unserer alleinigen Verantwortung für die Lieferung und Herstellung des Produktes Name des Produktes Model, Seriennummer Jahr der Herstellung auf welches sich dieses Dokument bezieht, stimmt mit den Vorgaben der folgenden Direktive, normativen Dokumente und deren jeweiligen Masstabe ein: 98/37/EC Maschinenriedirektive 73/23/EC Niederspannungsrichtlinie (nur zutreffend auf Produkte, die Strom benutzen)</p>	MT	<p>DIKJARAZZJONI TA KONFORMITA Ahna, Trelawny SPT Limited Niddikjaraw li ahna responsabbli kompletament għal provista / manifattura tal-prodott hawn imsemmi: Isem il-Prodott Mudell, Serial number Sena ta' produzzjoni Dan id-dokument magħmul għal prodott imsemmi hawn fuq, li huwa skond il-provizjonijiet imsemmija fid-dokumenti tal-klassi tax-xogħol: 98/37/EC Machinery Directive 73/23/EC Low Voltage Directive (tapplika biss għal prodotti li jaħdmu bl-elettriku)</p>
DK	<p>Erklæring om overensstemmelse Vi, Trelawny SPT Limited Erklærer hermed at under vores ene forhandling ansvar for vores forhandling/produktion af produktet Produkt navn Model, serie nummer Produktionsår For hvilket dette dokument referer, at det er i overensstemmelse med bestemmelser af følgende direktiver, normative dokumenter og deres relevante standard: 98/37/EC Machinery directive 73/23/EC Low voltage directive</p>	NL	<p>EENVORMIGHEIDSVERKLARING Wij, Trelawny SPT Limited Verklaart dat wij de volledige verantwoordelijkheid dragen voor het leveren/fabriceren van het volgende product. Naam van het product Type, Serienummer Productiejaar En verklaren dat het product waarnaar dit document verwijst eenvormig is met de voorzieningen van de volgende Richtlijn(en), Normatieve Documenten en hun relevante Standaarden: 98/37/CE MACHINERICHTLIJN 73/23/CE LAAGSPANNINGSRICHTLIJN (uitsluitend van toepassing bij producten die elektrische stroom gebruiken)</p>
EE	<p>TOOTE VASTAVUSE DEKLARATSIOON Meie, Trelawny SPT Limited Deklareerime, et vastutame järgmise varustuse/toote müügi eest Toote nimetus Mudel, Seeria number Aasta toodangu Antud dokument tõendab toote vastavust järgmistele direktiivide/le, normatiivaktidele ja nendega samaväärsetele standarditele: 98/37/EC MASINA DIREKTIIVID 73/23/EC MADALPINGE DIREKTIIVID (Kohandatakse vaid toodetele, mis kasutavad elektrivoolu)</p>	PL	<p>Deklaracja Zgodności My, Firma Trelawny SPT Limited, oświadczamy w naszej odpowiedzialności, że produkcja i dostawa urządzenia Nazwa produktu Model, numer seryjny Rok produkcji do którego ten dokument należy, jest zgodne z klauzulami następujących zarządzeń i ich istotnych standardów: 98/37/EC Zarządzenie mechaniczne 73/23/EC Zarządzenie niskiego napięcia elektrycznego (Zastosowanie tylko przy urządzeniach elektrycznych)</p>
ES	<p>Declaración de Conformidad Nosotros, Trelawny SPT Limited Declaramos que bajo nuestra completa responsabilidad de la fabricación/suministro del producto Nombre del Producto Modelo, No de Serie Año de producción A quien este documento se refiere, está de acuerdo con lo relacionado en la Directriz, Normativa Documentada y sus relevantes standards: 98/37/EC Directorio de Maquinaria 73/23/EC Directorio de Bajo Voltaje (Aplicable solamente a productos que funcionen con electricidad)</p>	PT	<p>DECLARAÇÃO DE CONFORMIDADE CE A empresa TRELAWNY SPT LIMITED Declara, sob sua inteira responsabilidade, que o fornecimento/fabrico do seguinte produto: Designação do produto Modelo, Número de Série Ano de produção a que esta declaração se refere, está em conformidade com o preceituado nas Directivas e Normas Comunitárias abaixo indicadas: 98/37/EC DIRECTIVA DE MÁQUINAS 73/23/EC DIRECTIVA DE BAIXA VOLTAGEM (Aplicável apenas a produtos que utilizam energia elétrica)</p>
FI	<p>ILMOITUSVAHVISTUS Me, Trelawny SPT Limited Vahvistamme tuotteiden toimittamisesta/valmistamisesta Tuotenimi Malli, sarjanumero Valmistusvuosi Tällä todistuksella vahvistamme säädökset seuraviin ohje/ohjesiin, Yleisiin papereihin ja niihin liittyvät vaatimukset: 98/37/EC KONEISTON OHJEET 73/23/EC PIENJÄNNITTE OHJEET (tarvitaan ainoastaan tuotteille jotka käyttävät sähkövoimaa)</p>	RU	<p>СВИДЕТЕЛЬСТВО О СООТВЕТСТВИИ Мы, Trelawny SPT Limited Заявляем, что несем полную ответственность за поставку/производство нижеуказанной продукции Наименование изделия Модель, серийный номер Год выпуска на которую выдано настоящее Свидетельство, и которая соответствует положениям следующей(их) Директив(ы), нормативным документам и относящимся к ним стандартам: 98/37/EC ДИРЕКТИВА ПО МЕХАНИЗМАМ 73/23/EC ДИРЕКТИВА ПО НИЗКОВОЛЬТНОМУ ОБОРУДОВАНИЮ (распространяется только на изделия с электропитанием)</p>
FR	<p>DÉCLARATION DE CONFORMITÉ Nous, soussignés Trelawny SPT Limited déclarons que le produit sous-nommé Nom du produit Modèle et Numéro de Série Année de production et pour lequel nous prenons entière responsabilité pour sa fourniture et manufacture, est conforme aux clauses des directives suivantes, documents normatifs et normes qui s'y appliquent: 98/37/EC DIRECTIVE POUR LA MACHINERIE 73/23/EC DIRECTIVE POUR BAS VOLTAGE (n'est applicable qu'aux produits utilisant l'énergie électrique)</p>	SE	<p>FÖRSÄKRAN OM ÖVERENSSTÄMMELSE VI, TRELAWNY SPT LIMITED FÖRKÄRLAR ATT VI MED ENSAMT ANSVAR ANSKAFFAT / TILLVERKAT PRODUKTEN PRODUKTNAMN MODELL och SERIE NUMMER Tillverkningsår TILL VILKEN DETTA DOKUMENT HÄNVISAR , ÄR I ÖVERENSSTÄMMELSE MED FÖLJANDE DIREKTIV , NORMATIVA DOKUMENT OCH DERAS RELEVANTA STANDARDER 98/37/EC MASKINDIREKTIV 73/23/EC LÅGSTRÖMSDIREKTIV (TILLÄMPLIG PÅ ELEKTRISK DRIVNA PRODUKTER)</p>
GR	<p>ΔΗΛΩΣΗ ΠΙΣΤΟΤΗΤΑΣ Η εταιρεία Trelawny SPT Limited Δηλώνει ότι έχει τη μοναδική ευθύνη ως κατασκευαστρια / προμηθευτρια του παρακάτω προϊόντος περιγραφή προϊόντος μοντέλο, αριθμός σειράς έτος παραγωγής και στο οποίο αναφέρεται αυτή η δήλωση, είναι συμβατο με τις προδιαγραφές που ορίζονται στις ακόλουθες Κοινοτικές Οδηγίες Ελεγκτικές Διατάξεις κι άλλες σχετικές προδιαγραφές 98/37/EC ΟΔΗΓΙΑ ΠΕΡΙ ΜΗΧΑΝΗΜΑΤΩΝ 73/23/EC ΟΔΗΓΙΑ ΠΕΡΙ ΧΑΜΗΛΗΣ ΤΑΣΗΣ (αφορά μόνον προϊόντα που λειτουργούν με ηλεκτρικό ρεύμα)</p>	SI	<p>IZJAVA O SKLADNOSTI Trelawny SPT Limited pod polno odgovornostjo izjavljamo, da so spodaj navedeni proizvodi, ki jih dobavljamo/proizvajamo: Ime proizvoda Model, serijska številka Leto proizvodnje na katere se ta dokument nanaša, proizvedeni v skladu z določili naslednjih direktiv, normativnih dokumentov in njihovih relevantnih standardov: 98/37/EC DIREKTIVA O STROJIH 73/23/EC DIREKTIVA O STROJIH Z NIZKO VOLTAŽO (nanaša se samo na proizvode na električni pogon)</p>
HU	<p>MEGFELÉLŐSÉGI NYILATKOZAT Mi, A "Trelawny SPT Limited" cég Felelősségünk tudatában kijelentjük, hogy mint a termék szállítója/gyártója Termék neve Típus, Sorozatszám Gyártási év amelyre jelen dokumentum vonatkozik, megfelel az alábbi irányelv(ek), Irányadó Dokumentumok előírásainak, és az azokat meghatározó szabványoknak: 98/37/EC GÉPÉSZETI IRÁNYELVEK 73/23/EC KISFESZÜLTÉSŰ IRÁNYELVEK (Csak az elektromos meghajtású gépeknél)</p>	TR	<p>UYGUNLUK BEYANI Trelawny SPT Limited Aşağıdaki, üretim ve tedarikinden tek başına sorumlu olduđu ürünün Ürün adı Model/Seri no Üretim yılı bu belgenin ilgili olduđu aşağıdaki yönetmeliklerin, norm belgelerinin ve ilgili standartlarının kopullarına uygun olduđunu beyan eder: 98/37/EC MAKÝNALAR YONETMELÝĐÝ 73/23/EC DÜPÜK GERÝLYM YONETMELÝĐÝ (Yalnızýz elektrikle çalıřan ürünlerde geçerlidir)</p>
IT	<p>DICHIARAZIONE DI CONFORMITÀ La Società Trelawny SPT Limited Dichiara, sotto la propria responsabilità, che la fornitura / produzione del prodotto Nome prodotto Modello, codice Anno di produzione a cui si riferisce tale documento è conforme alle seguenti Direttive, ai documenti della Normativa ed ai relativi standard: 98/37/EC DIRETTIVA SULLE APPARECCHIATURE 73/23/EC DIRETTIVA SUL BASSO VOLTAGGIO (applicabile esclusivamente per i prodotti che utilizzano energia elettrica)</p>		

INFORMATION

General Information

Before operating Trelawny Triple Scabbling Hammer, this manual must be read and understood by the operator, if in any doubt, ask your supervisor before using this equipment. Local safety regulations must be followed at all times. Failure to follow these instructions could result in damage to the Scabblers and/or personal injury.

Trelawny SPT Ltd disclaims all responsibility for damage to persons or objects arising as a consequence of incorrect handling of the tool, failure to inspect the tool for damage or other faults that may influence its operation prior to starting work, or failure to follow the safety regulations listed or applicable to the job site.

The Triple Scabbling tool is fitted with either bush or cruciform cutter heads and is primarily designed for concrete reduction and the removal of laitance from concrete, It can also be used for the removal of heavy rust and scale.

Note: Bush Hammer style headed pistons are best suited to concrete reduction and for laitance removal; these reduce the damage caused to the aggregate using the cruciform cutter head, ensuring that a strong bond is created with the next layer.

Cruciform headed pistons are best suited for the removal of heavy rust and scale and also in the reduction of concrete where a smoother finish is required; this type of piston will reduce the aggregate as well as the concrete surface.

Air Supply

The compressed air must be free from water and dirt. The installation of a filter/regulator/lubricator air preparation set (with moisture trap) adjacent to the tool is strongly recommended.

Always clear the air hose before connection to the tool. Ensure that no moisture (condensation) is present in the air hose.

Ensure that a minimum 10mm (3/8") bore air hose is used and that all couplings are secure, leak free and in good condition.

Limit the length of air hose to 10M (33ft). Where extra length is necessary, for each additional 15M (50ft) of air hose used, the pressure drop is approximately 0.16bar (3psi).

Correct operating pressure is 6.2bar (90 psi).

Do not let the operating pressure fall below 5.5bar (80p.s.i.) or rise above 6.9bar (100 psi) absolute maximum.

The compressor must be able to supply a minimum of 14.2lps (30cfm), (Free air, not displaced as quoted by some compressor manufactures).

In particularly cold weather it is recommended that a proprietary anti-freeze lubricating oil is used.

Safety

Always, read instructions first before use.

Do wear Personal Protective Equipment including safety goggles, footwear, ear defenders and gloves. In some environments it will be necessary to wear facemasks or breathing apparatus.

Do be aware that this tool is not electrically insulated.

Do keep hands and clothing away from moving parts.

Do ensure that this tool is lubricated daily.

Do be aware that the tool can create dust and flying debris.

Do be aware of others working around you.

Do store this tool in a secure and dry environment.

Always observe safe-working practices at all times.

Do not allow the tool to run unattended.

Do not use this tool in potentially explosive environments.

Do not drag this tool by the air hose.

Do not use the Scaler as a lever.

Do not use petrol (gasoline), thinners or any other high flash point solvent to clean the tool.

Do not modify this tool in any way, as this will invalidate the warranty and could lead to serious injury.

Risk of Hand-arm Vibration injury

These tools may cause Hand-arm Vibration Syndrome injury if their use is not adequately managed. We advise you to carry out a risk assessment and to implement measures such as; limiting exposure time [i.e. actual trigger time, not total time at work], job rotation, ensuring the tools are used correctly, ensuring the tools are maintained according to our recommendations, and ensuring that the operators wear personal protective equipment [PPE] **particularly gloves and clothing** to keep them warm and dry.

Employers should consider setting up a programme of health surveillance to establish a benchmark for each operator and to detect any early symptoms of vibration injury.

We are not aware of any PPE that provides protection against vibration injury by attenuating vibration emissions.

See 'Specifications' section for vibration emission data.

Further advice is available from our Technical Department.

Recommended lubricants

Oil the tool daily before use. Put a few drops of one of the following zinc free air tool lubricants through the air inlet.

SHELL	S22 or R10
CASTROL	Hyspin ZZ32

Cleaning

At intervals of no more than 40 hours or if operation becomes unproductive and the piston shows signs of sticking, dismantle and clean with a highly refined paraffin.

Immediately after cleaning, thoroughly oil the tool with one of the recommended lubricants.

MAINTENANCE

Starting work

Prior to operating the tool check: -

That all fittings are secure, free from leaks and air hoses are in good condition.

That the air pressure is correct for this tool 6.2 bar (90p.s.i.). Put a few drops of recommended lubricant into the air inlet of the tool.

To operate the tool, which is dependant on the type of lever fitted, for those fitted with a safety lever, first push thumb button forwards and then for both styles of lever, pull the lever towards the handle grip to start the tool, then apply the cutter heads to the surface being prepared.

To switch off, simply release the throttle lever.

Care must be taken to avoid damaging or tripping over the air hose. Maintain contact with the work surface with sufficient pressure only to keep the tool from bouncing off. Excessive pressure can prevent the tool from working to its full capacity. Handled correctly the Scaler will work quickly and efficiently.

Excessive operator pressure will not improve the tool efficiency but will cause premature tool failure and operator fatigue.

Never allow the tool to run continuously whilst not in contact with the surface being prepared.

Maintenance

Maintenance must only be carried out by a competent person.

Disconnect the tool from the air supply before carrying out any of the following operations.

Clean all debris from the exterior of the tool.

Piston removal

Hold the Pistons (avoid clamping on the ground surfaces) in a soft fibre jaw vice, with the Backhandle uppermost and the main Handle away from you.

Remove the four Allen headed screws securing the overhead handle or weight.

Remove the three O'Rings (18) and Cylinder Nylon Pads (17) from top of the cylinders.

(Discard the O'Rings and replace with new).

Remove tool from the vice. From the bottom of the body, push up on the cutter head end of the Piston (16). Inspect all parts for wear, particularly the Cylinder Sleeve (15) bores.

Check the Pistons ground diameters, and tungsten carbide tips for wear.

Check the ground surfaces on both the Cylinder Sleeves and Pistons for wear, and for score marks caused by grit or other foreign bodies.

Replace any worn components or any showing signs of scoring as necessary.

Note: For most applications, the expected life of the tungsten carbide cutters is approximately 100hrs.

Valve body servicing

Clamp the assembly firmly in a soft face jawed vice, using the flats provided on the Valve Body (6), with the Throttle Lever (7) upper most.

Using a 3mm diameter pin punch, remove the Throttle Lever Roll Pin (8), and then remove the Throttle Lever (7).

Rotate the tool 180 degrees in the vice to access the valve.

Using a screwdriver, unscrew the Valve Cap (1), check the Valve Cap's O'Ring (2), remove the Spring (3), remove the Valve Stem (4) and the Valve seat O'Ring (5). Check the Valve Stem and O'Ring for wear.

Assembly

Before any assembly takes place, ensure all parts are clean and are coated in a thin film of recommended air tool lubricant.

It is strongly recommended that the Nylon pad O'Rings (18) and any other worn parts be replaced before assembly.

Valve Body assembly

Clamp the assembly firmly in a soft face jawed vice, using the flats provided on the Valve Body (6), insert new Valve Seat O'Ring (5) into Valve Body, followed by the Valve Stem (4), Spring (3), then the Valve Cap (1) complete with its O'Ring (2), and tighten the Valve Cap with a screwdriver.

Rotate assembly 180 degrees in vice. Using a 3mm diameter pin punch locate and align the Throttle Lever (7) in position, then drive in the Throttle Lever Roll Pin (8) into the Pin location.

Piston and Sleeve assembly

Press or lightly tap the new sleeves into place using a soft faced hammer and a suitable drift or use an old piston reversed.

Lubricate the piston (16) and Cylinder Sleeve (15) bores, then insert the Piston into the bore.

Hold the Pistons (avoid clamping on the ground surfaces) in a soft fibre jaw vice, with the Backhandle (19) uppermost and the main handle (3) away from you.

Fit the cylinder Nylon Pads (17) on top of the pistons cylinder bore with its stepped section uppermost, then fit **new** O'Rings (18) on top of the cylinder Nylon Pads.

Screw down the Backhandle (19) evenly, use a medium strength thread locking adhesive on the first few threads of each of the 4 x M8 cap head screws (20) such as Loctite 243, tighten using a 6mm Allen key.

Disposal

When the tool and its accessories are taken out of service for disposal, it is recommended that: -

They are rendered unusable to prevent improper re-use.

They are dismantled into component form, segregated according to material composition and disposed of using waste recycling processes specified by local regulations.

EXPLODED DIAGRAM

EXPLODED DIAGRAM

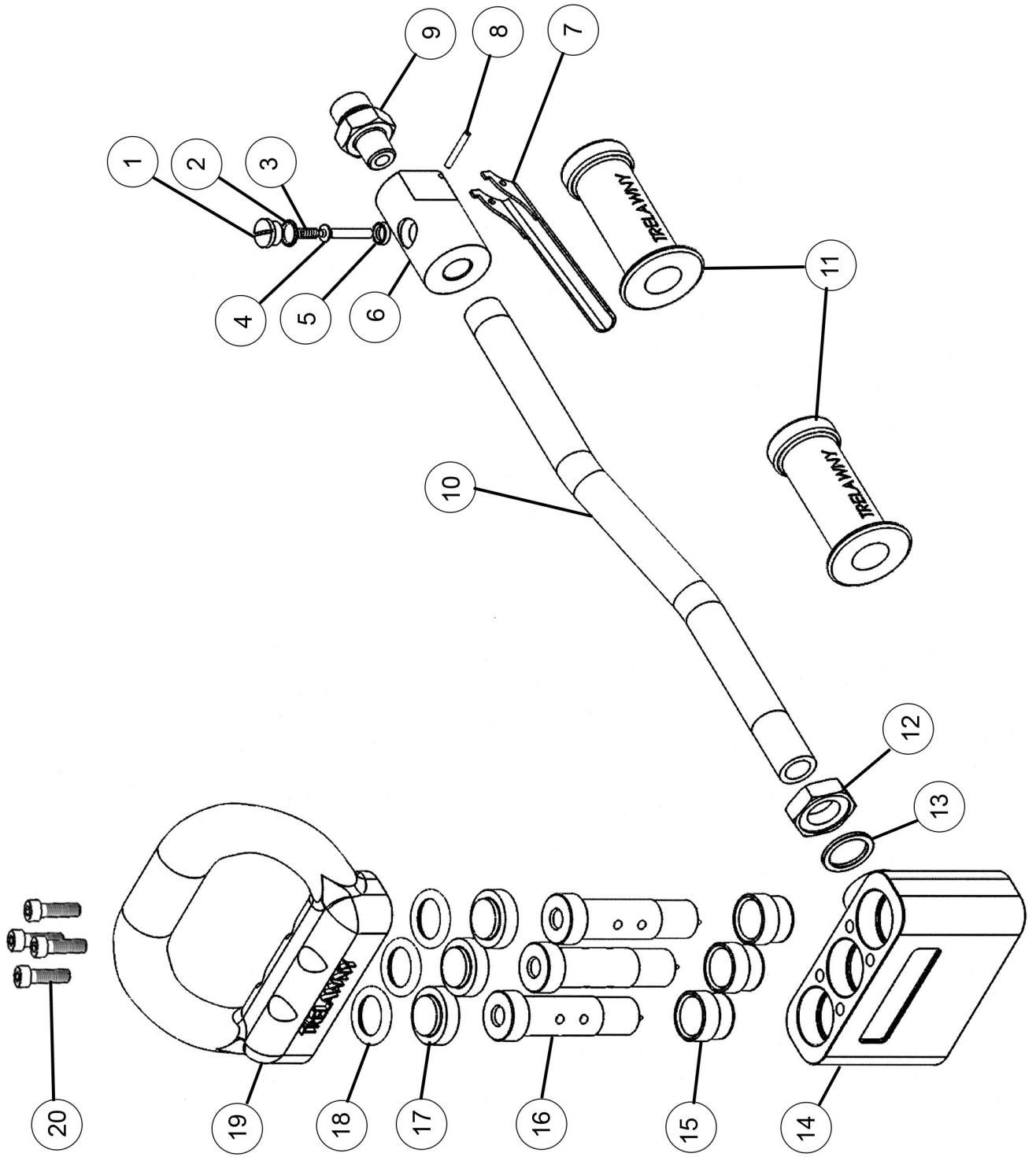

PARTS LIST

Item	Part Number	Description
1	615.3021	Valve Cap
2	809.0139	O'Ring - Valve Cap
3	712.3022	Valve Spring
4	618.3022	Valve Stem
5	809.0089	Square O'Ring - Valve Seat
6	423.5321	*Valve Body Assembly (includes items 1-8)
7	716.3000	Throttle Lever
	716.1000	*Throttle Lever Safety
8	813.0108	Roll Pin
9	711.5301	Airline Adapter
10	624.5301	Tube Handle
11	717.3060	Rubber Grip (2 x required)
12	625.5301	Locknut
13	810.9001	Sealing Washer
14	411.6220	Standard Body (Includes item 15)
15	613.5370	Sleeve (3 x required)
16	612.6010	Piston One Piece - TCT Bush Hammer (Fitted as standard) (3 x required)
	612.6000	*Piston One Piece - TCT Cruciform (3 x required)
17	615.6005	Nylon pad (3 x required)
18	809.6229	Cylinder O'Ring (3 x required)
19	611.6040	Backhandle
20	806.0830	M8 x 30 cap head Screw (4 x required)
		*Items not shown on exploded diagram
	719.1000	*3/8" Bore Hose (10 metre)
	719.3000	*3/8" Bore Hose (30 metre)

TROUBLE SHOOTING		
Poor performance or lack of power	Low air pressure.	Ensure that the air pressure is correct at 90psi, max 100psi.
	If tool has been left for some time without use, the oil may dry out slightly causing a sticky residue.	Strip tool down and re-oil.
	Tool worn out, can you feel side ways movement between the piston and cylinder bore.	Replace the piston and cylinder, along with a new bush seal.
Tool continues to run with trigger released	Valve seal may have become dislodged through the tool being disconnected with the trigger in the open position.	Ensure that the trigger has not been taped or wired in the open position. Do not use quick release couplings to switch tool off.

TECHNICAL SPECIFICATIONS

Piston Diameter	27.5mm (1.08")
Piston Length	87.4mm (3.44")
Piston Stroke	39.8mm (1.57)
Blows Per Minute	2800
Air Consumption	7.5 lps (16cfm)
Air Pressure	6.2 bar (90 psi)
Length	460mm (18.0")
Height	220mm (8.6")
Weight	4.8 kg (10.4 lbs)
Noise Level	L_{pA} dB (A)
	L_{wA} dB (A)
	98.5
TRIPLE SCABBLER BACK HANDLE	
Vibration Level Bush Piston (Trigger Hand) Primary	15.53 m/s ² (K= 4.14m/s ²)
Secondary	48.49 m/s ² (K= 5.43m/s ²)
Vibration Level Cruciform Piston (Trigger Hand) Primary	13.31 m/s ² (K= 2.37m/s ²)
Secondary	46.55 m/s ² (K= 7.38m/s ²)

Declared vibration emission value are in accordance with BS EN ISO 28927 and BS EN ISO 20643
(K) Equals the factor of uncertainty, which allows for variations in measurement and production.
Vibration data figures are tri-axial, which gives the total vibration emission.

Risk of Hand Arm Injury

Because of various factors, the range of vibration emission during intended use of the back handle tool is expected to be between 48.5m/s² - 67.9m/s².
Because of various factors, the range of vibration emission during intended use of the vibration reduced tool is expected to be between 20.07m/s² - 28.1m/s².

The vibration is dependent on the tool model, task, the operators grip, and feed force employed etc.

Noise level measured in accordance with: EN ISO 15744: 1999
Vibration measured in accordance with: EN ISO 28927 and EN ISO 20643

Machinery Directive Information

This machine has been designed and produced in accordance with the following directives: 2006/42/EC Machinery Directive and applicable harmonised standard: EN ISO 1 1148-4:2010

Trelawny tools are thoroughly tested under specified conditions in accordance with applicable internationally recognised standards.
When a tool is used on site the conditions may not be the same as those used in our tests.

Trelawny Surface Preparation Technology operates a policy of continuous product development and refinement and therefore reserves the right to change technical specifications and product designs without giving prior notice.

© Copyright 2013, Trelawny SPT Limited, CV31 1XT. UK All rights reserved. Any unauthorised use or copying of the contents or part thereof is prohibited. This applies to trademarks, model denominations, part numbers and drawings.
Use only genuine Trelawny spares.

The use of non-Trelawny spare parts invalidates the warranty.

Trelawny SPT Ltd
13 Highdown Road, Sydenham Industrial Estate, Leamington Spa,
Warwickshire, CV31 1XT, United Kingdom
Telephone: +44 (0)1926 883781 - Fax: +44 (0)1926 450352
Email: sales@trelawny.co.uk

© TSPT UK 2013 Part No: 735.2338 issue 13.2.17



www.trelawnyspt.co.uk